

FOR USE ONLY IN APPROVE LOCATIONS

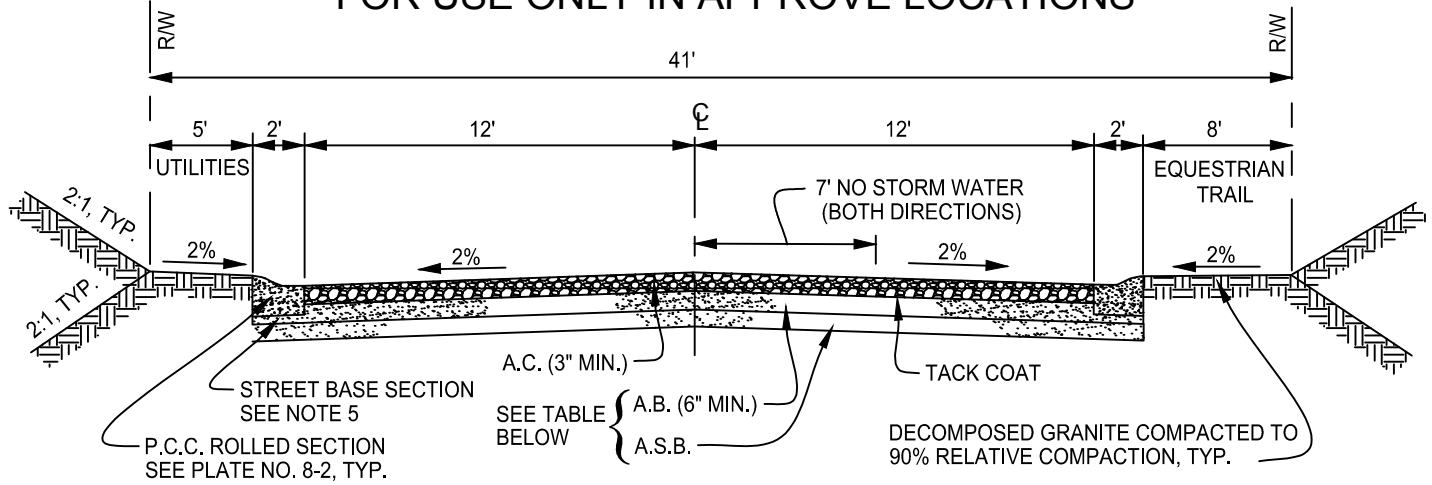

CROSS SECTION
NOT TO SCALE

DESIGN CRITERIA:

DESIGN SPEED	25 M.P.H.
CURVE RADIUS	200' MIN.
GRADIENT	0.6% MIN. - 15.0% MAX. OR AS DETERMINED BY PUBLIC WORKS DIRECTOR
STOPPING SIGHT DISTANCE	150' MIN.
INTERSECTION SIGHT DISTANCE	275' MIN. SEE PLATE NO. 3-10
SUPERELEVATION	NONE
TRAFFIC INDEX	6.0
LENGTH OF VERTICAL CURVE	SEE PLATE NO. 3-8

DRAINAGE:

SEE "1" SERIES PLATES

TABLE FOR A.B./A.S.B.

BASEMENT SOIL 'R' VALUE	> 42	37-42	32-36	27-31	22-26	17-21	12-16	7-11	< 7
A.S.B. THICKNESS WHEN USED WITH 6" A.B.	_____	_____	_____	4"	5"	6"	7"	8"	9"
ALTERNATE - A.B. ONLY	6"	7"	8"	9"	10"	11"	12"	13"	14"

NOTES:

- LOCAL PURPOSE ROAD PROVIDES ACCESS TO 15 DWELLING UNITS OR LESS, 1,600' OR LESS IN LENGTH AND BEGINNING AND ENDING IN THE SAME CROSS ROAD; OR DEAD END ROAD PROVIDES ACCESS TO 15 DWELLING UNITS AND NOT EXCEEDING 800' IN LENGTH MEASURED FROM THE CENTER OF TURNAROUND TO CENTER OF INTERSECTING ROAD.
- P.C.C. PAVEMENT REQUIRED FOR GRADES OF 15% OR MORE. P.C.C. PAVEMENT DESIGN TO BE APPROVED BY THE CITY ENGINEER.
- OFF STREET PARKING SHALL BE REQUIRED AS DETERMINED BY THE PLANNING COMMISSION. ON STREET PARKING IS PROHIBITED.
- STREET TREES SHALL BE REQUIRED.
- BASE UNDER CURB AND GUTTER SHALL EXTEND TO SAME DEPTH AS STREET BASE (6" MIN.).
- EQUESTRIAN TRAIL SHALL PROVIDE 8' WIDTH, CLEAR OF ANY OBSTRUCTIONS.
- THE CITY TRAFFIC ENGINEER MAY REQUIRE MODIFICATIONS TO PROPOSED, LANDSCAPING, BERMS, SLOPES, STREET FURNITURE, WALLS OR STRUCTURES WITHIN THE SIDEWALK OR PARKWAY AREA, AS WELL AS OUTSIDE OF THE PUBLIC RIGHT-OF-WAY WITHIN 500' OF ANY INTERSECTION TO COMPLY WITH SIGHT DISTANCE REQUIREMENTS.

CHANGE	DESCRIPTION	DATE	INITIAL	APPROVED: 	DATE: 5/24/18
--------	-------------	------	---------	---	---------------